

# MASTER ABRASIVES

## Centreless Grinding Machine

CASE STUDY

#1026

<b>Workpiece:</b>	Shaft
<b>Machine:</b>	Micromatic CLG 5020
<b>Cycle Time:</b>	45 seconds
<b>Stock Removal:</b>	0.15mm
<b>Dimensional Tolerance:</b>	0 /- 0.018mm
<b>Roundness:</b>	<3 $\mu\text{m}$
<b>Surface Roughness:</b>	< Rz 6.3
<b>Dressing Skip:</b>	50 components

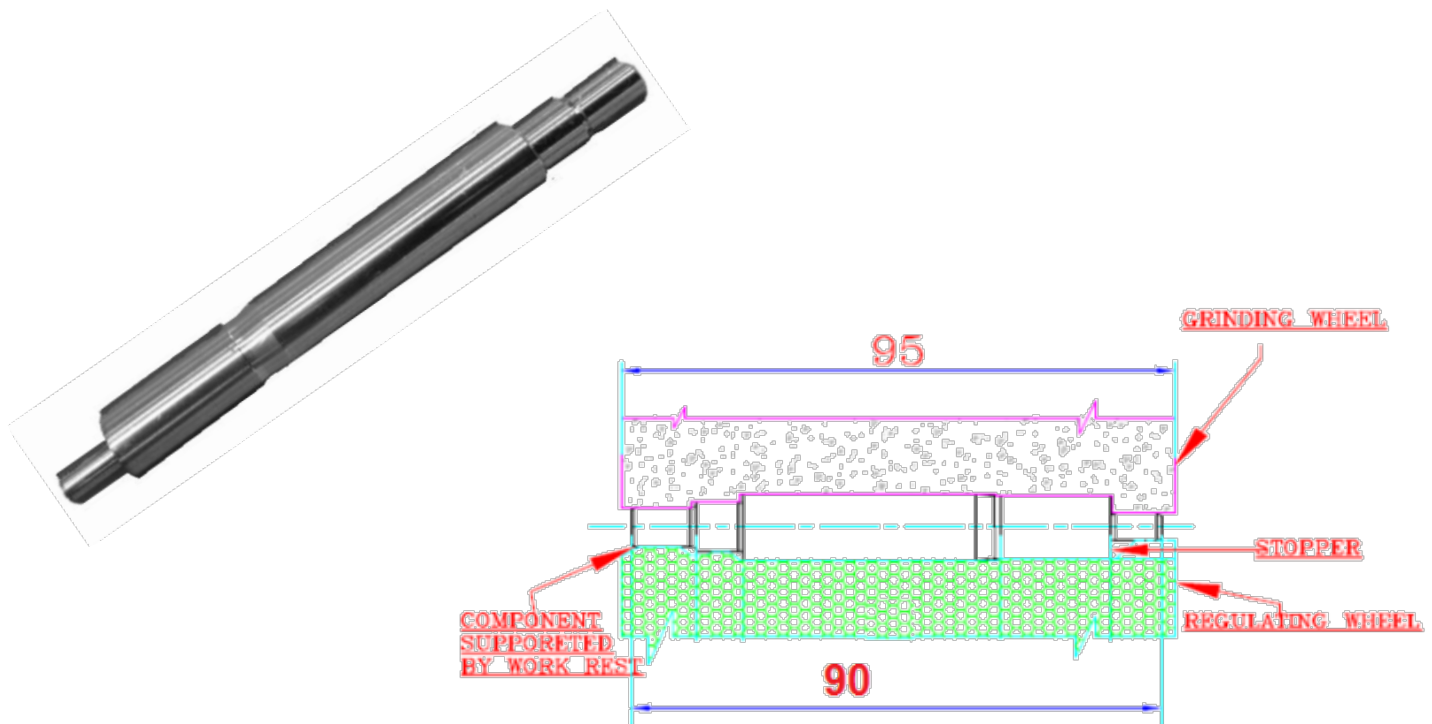

Copyright © 2020 Master Abrasives Ltd

CONTACT US FOR MORE INFORMATION

# MASTER ABRASIVES

T:01327-703813

sales@master-abrasives.co.uk

www.master-abrasives.co.uk